

**SPECIFICATION
POWER PRO SPECIFICATIONS
Part Number: PO-RPP1**

GENERAL

These specifications are to cover the minimum specifications for a single-line, single color, paint striping machine with hydraulic powered airless paint system capable of applying traffic marking materials of all types, both solvent based and waterborne.

EQUIPMENT

1. **FRAME AND CHASSIS.** The main frame shall be made of heavy duty tested pipe, 1 7/8" O.D. The handles shall be manufactured with tested pipe, 1/8" wall thickness, 1 1/6" O.D. The motor and pump shall be mounted on a specially designed engine deck. The unit shall be 56" long, 37" wide, 40" high and weighs 250 lbs.
2. **ENGINE.** The marking machine shall be equipped with a single cylinder, four cycle, air-cooled, gasoline engine Honda Model GX-120 capable of developing not less than 4.0 gross horsepower at 3600 RPM. The engine shall be equipped with a large capacity .66 gallon all-steel gas tank. The engine shall be overhead valve design and equipped with an oil alert. The line marking machine shall be equipped with an all-steel expanded metal belt and pulley guard.
3. **HYDRAULIC SUPPLY PUMP AND RESERVOIR.** The hydraulic supply pump shall have a minimum capacity of 4.5 GPM at 900 RPM. The pump shall be pressure compensated type dedicated exclusively to powering the airless paint pump. Mechanical clutch driven pump shall not be permitted. Unit shall have an integral oil reservoir. Reservoir shall be constructed of aluminum and shall incorporate cooling fins. Reservoir shall be a two-piece design with removable top to allow for easy clean out. Hydraulic system shall incorporate a replaceable, canister type oil filter. The hydraulic system shall include a built-in pressure adjustment valve to allow a full range of pressure adjustment from 400 PSI to 3000 PSI paint pressure.
4. **AIRLESS PAINT PUMP.** The hydraulic paint pump shall be hydraulically powered, reciprocating piston pump (NO EXCEPTIONS). Paint output capacity shall be 1.25 GPM at 60 cycles. Piston rod and cylinders shall be hard chrome plated for corrosion and abrasion resistance. The pump packing shall be spring-loaded and use both ultra high molecular weight polyethylene and thiokol impregnated leather packing. (Mechanically driven airless pump assemblies that utilize a clutch are not acceptable and will not be considered.).
5. **HIGH PRESSURE AIRLESS PAINT FILTER.** One high pressure airless paint filter shall be provided. The filter will be piped directly to the outlet of the high pressure airless paint pump and feature a removable filter screen and check valve. The filter will have a filtration area of not less than 18 square inches. A pressure bleed valve will be provided complete with handle style knob and bleed hose.
6. **SPRAY GUN.** The paint marking machine shall be equipped with a single airless spray gun with stainless steel fluid passage and .90" carbide ball and seat. The spray gun shall be equipped with

Reverse-A-Clean spray tips to allow the gun tip to be cleaned or unclogged easily and without the use of tools. The spray gun shall be equipped with two tips: (1) .219" orifice spray tip suitable for painting 4"- 6" traffic lines and (1) .517 orifice spray tip suitable for general spraying and large stencils. The tips shall be capable of applying either alkyd or latex materials. The spray gun shall be equipped with no less than 50' of 1/4" airless paint hose with a working pressure of 3,000 psi and with spring guard protectors at each fitting.

7. **STRIPING GUN LOCATION.** The striping gun(s) shall be located on the front right or left side of the machine. All vertical and horizontal gun adjustments shall be accomplished with the use of no tools required knobs. Bead dispensers if equipped, shall be placed directly behind each striping gun(s). All vertical and horizontal bead gun adjustments shall be accomplished with the use of hand tools. Bead gun location shall be adjustable (forward to back) to allow precise bead deposition of glass beads anywhere from 0" to 10" from the sprayed paint pattern.
8. **WHEELS.** The rear wheels shall be not less than 4.00 x 8 tubeless type pneumatic equipped with 1-3/8" anti-friction roller bearings and mounted on 3/4" diameter axle. The rear axle assembly shall be spring-loaded with adjustable tension to lock rear wheels for straight striping. The front wheel shall be 3.00 x 5 tube type pneumatic tire equipped with 5/8" ball bearings.
9. **CONTROLS.** The striping gun(s) shall be controlled by a "squeeze & lock" handle assembly located on the right handle bar of the unit. The handle will be attached directly to the cable assembly leading to the spray gun activator assembly. The handle will be equipped with a selector pin capable of activating a single striping gun or simultaneously activating an optional second paint gun. The handle assembly shall be equipped with a spring loaded ball assembly to lock the spray gun(s) in the on position. Paint pump on/off valve, and a prime/pressure relief valve will be located near the high-pressure paint pump allowing positive control of the pump and paint flow. A hydraulic pressure adjustment will be located on the hydraulic pump.
10. **FRONT LOCKING SWIVEL WHEEL.** The striping machine shall be equipped with a front swivel wheel assembly with heavy-duty locking device. An activation handle shall be provided on the left handle to engage and disengage the swivel lock. The locking pin base shall be machined from 1-1/4" thick 6061 aluminum block. The locking pin shall be machined from .625" CD square and be engaged in the aluminum a minimum of 4" to prevent any movement of the front wheel when locked for straight striping. The aluminum block will be equipped with slotted holes to adjust the front swivel wheel for straight tracking. Non adjustable swivel wheels shall not be permitted.
11. **PAINTING.** The line marking machine shall be painted Federal Highway Yellow.
12. **GUARANTEE.** Kelly-Creswell products carry a one year warranty against defective parts and workmanship
13. **SERVICE MANUALS.** One complete set of operating instructions and repair parts list shall be delivered with the unit. Detailed parts drawings with part numbers shall be provided.

OPTIONAL EQUIPMENT

Paint Tanks		A 7 or 12 gallon zero pressure paint tank will be provided in lieu of the pail holder. The tank will include a 10" lid assembly and material will draw from the bottom of the paint tank thru a 3/4" "Y" type strainer to the inlet of the high pressure airless paint pump. A shut off valve will be provided at the outlet of the tank for cleaning the strainer and a second drain valve will be provided to drain paint from tank. The tank lid will feature a bung for the pressure drain wand.
	AC-1340-SS	7 gallon all stainless steel paint tank with stainless steel plumbing and "Y" strainer.
	AC-1345-SS	12 gallon all stainless steel paint tank with stainless steel plumbing and "Y" strainer.
Tank Agitators		
	AC-1130	Hand paddle agitator for 7 or 12 gallon tanks, plated carbon steel shaft with plastic paddles and hand crank.
	QM-1011-1-SS	SS shaft for AC-1130 (recommended for latex material).
Striping Guns	AC-1300	The marking machine can be equipped with a second airless spray gun complete with a .219 orifice spray tip. The assembly shall include the gun, telescoping gun carriage, gun holder and 38" of airless hose. The mounting of the second gun shall be such that, the guns can be mounted together on either side of the machine or on opposite sides, with a maximum distance apart of 33" on one side of the machine. The guns may be used together to apply a maximum line width of 24" with the proper tip installation.
Gravity Bead Dispenser		The line marking machine shall be equipped with up to (2) 4" or 6" automatic glass bead dispensers, all-steel 50 pound capacity bead hopper. The bead dispenser shall be installed to operate automatically in conjunction with the striping gun by means of the same mechanical lever. The bead dispenser(s) shall be fully adjustable for the desired application ratio of pounds of beads per gallon of paint. Bead dispenser(s) shall be mounted on a sliding and retractable gun bar. All bead dispenser adjustments shall be completely independent and not interfere with the striping gun adjustment. The bead hopper shall be of 16 ga. sheet metal construction with a hinged lid with latch. The hopper shall be mounted on a structural steel tube permitting the hopper discharge to be located on either side of the machine. The hopper shall be easily removable via a telescoping tube mount.
	AC-1051-4-RP	(1) 4" Gravity Dispenser & 50# Hopper.
	AC-1051-6-RP	(1) 6" Gravity Dispenser & 50# Hopper.
	AC-1052-4-RP	(2) 4" Gravity Dispensers & 50# Hopper.
	AC-1052-6-RP	(2) 6" Gravity Dispensers & 50# Hopper.
Pressure Bead System		See Heavy Duty Powerstroke self propelled airless striper.
Parking Brake	AC-1211	One (1) hand parking brake assembly installed to secure the machine when unattended.
Transport Trailer	AC-1260	Model K transport trailer, single axle trailer complete with fold down ramp and tie down straps for striping equipment.
Spare Parts	PO-RPP1-	Spare parts inventory including 235-474 rebuild kit for spray gun, two

Inventory	Minor	additional HDPT-01 tip guards, 5-1-150 one quart pump lubricant, 700-889 winterize kit for pump, 930-006 replacement high pressure filter cartridge.
	PO-RPP1-Major	Spare parts inventory recommend for export customers includes Minor kit plus, 6247 6' airless hose assembly, 6242 50' airless hose assembly, complete set of belts, 107-051 packing kit for airless pump, 6196 one each rear wheel, 6197 one each front wheel assembly, GX-120 Air Filter engine air filter, BPR6ES spark plug, 451-220 hydraulic filter.
Crating	PO-Crate	Crating charge for all portables shipped common carrier. Includes heavy wooden skid with protective frame.
	PO-Crate-Export	Fully enclosed wooden box fabricated, 7/16 OSB wood.

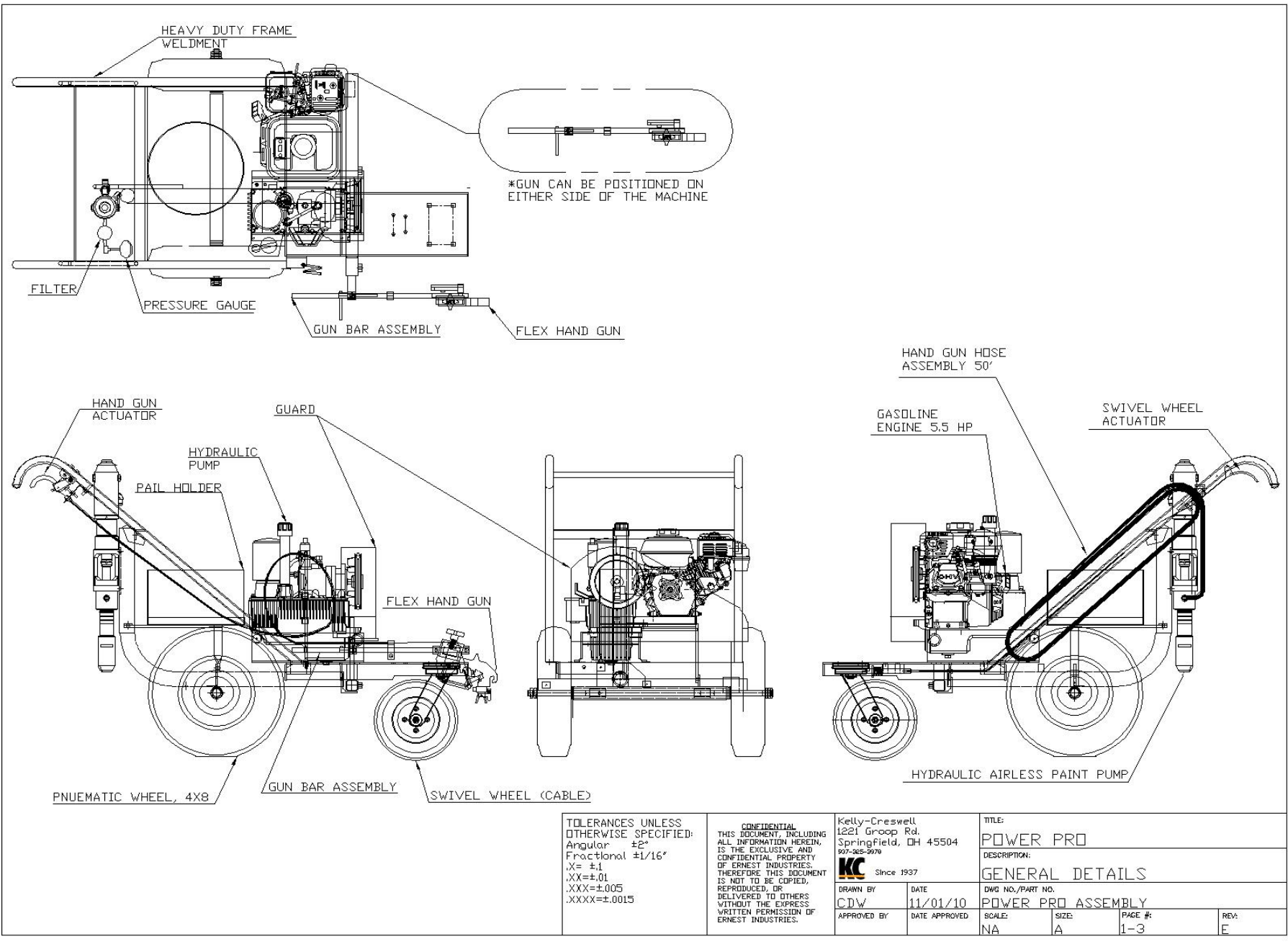

Kelly-Creswell
 Power Pro
 Rev C

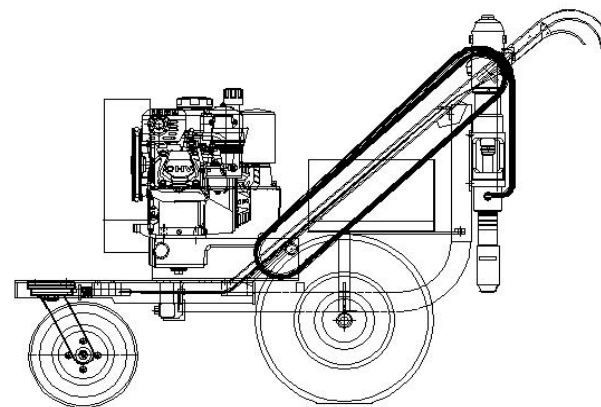
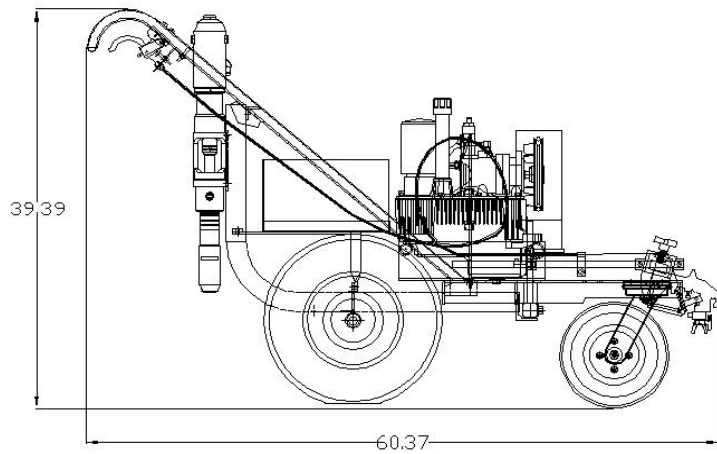
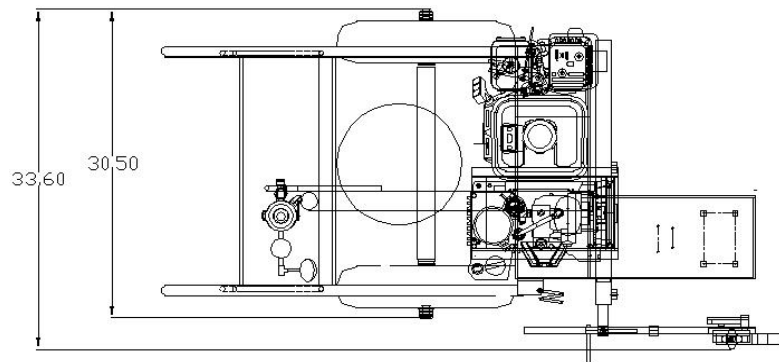

TOLERANCES UNLESS OTHERWISE SPECIFIED: Angular $\pm 2^\circ$ Fractional $\pm 1/16"$.X = ± 1 .XX = ± 0.1 .XXX = ± 0.005 .XXXX = ± 0.0015	CONFIDENTIAL THIS DOCUMENT, INCLUDING ALL INFORMATION HEREIN, IS THE EXCLUSIVE AND CONFIDENTIAL PROPERTY OF ERNEST INDUSTRIES. THEREFORE THIS DOCUMENT IS NOT TO BE COPIED, REPRODUCED, OR DELIVERED TO OTHERS WITHOUT THE EXPRESS WRITTEN PERMISSION OF ERNEST INDUSTRIES.	Kelly-Creswell 1221 Groop Rd. Springfield, OH 45504 937-265-2979	TITLE: POWER PRO			
		 Since 1937	DESCRIPTION: BASIC DIMENSIONS			
DRAWN BY CDW	DATE 11-2-10	DWG NO./PART NO. POWER PRO ASSEMBLY	SCALE: N/A	SIZE: A	PAGE #: 2-3	REV: A

Kelly-Creswell
 Power Pro
 Rev C

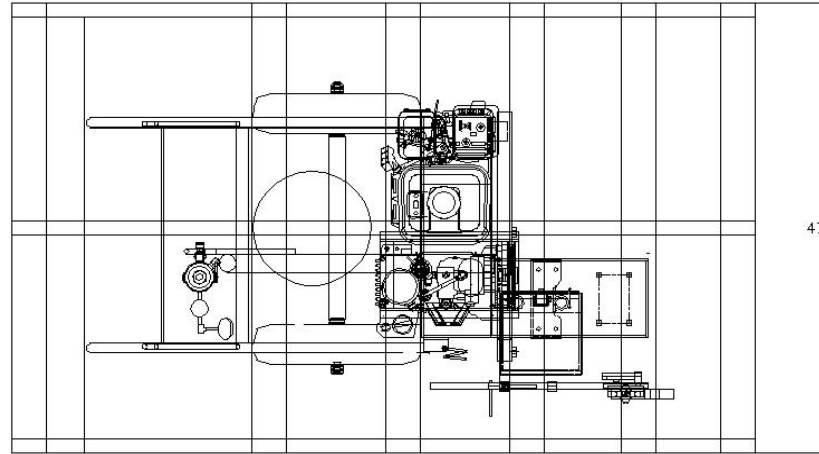

47.00

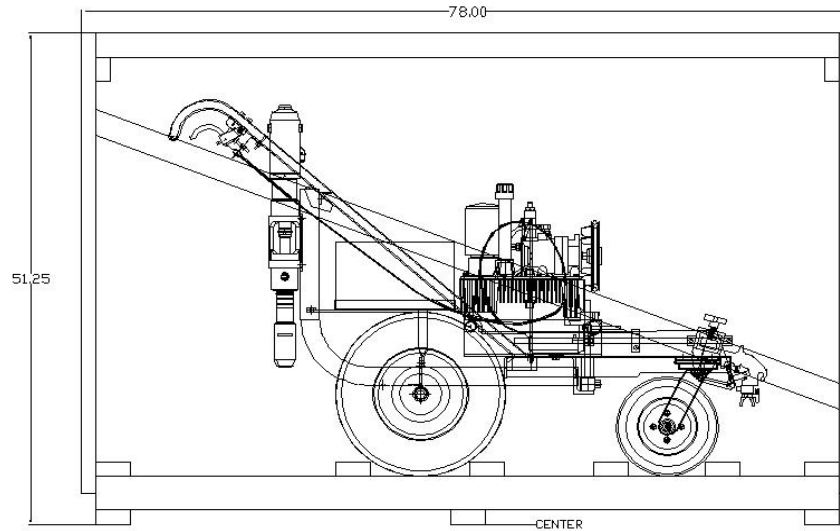

78.00

51.25

CENTER

LENGTH (INCHES)	78"
WIDTH (INCHES)	47"
HEIGHT (INCHES)	51.25"
EST. SHIPPING WEIGHT	400 LBS
APPROX. CUBIC FEET	105'

TOLERANCES UNLESS OTHERWISE SPECIFIED:
 Angular ±2°
 Fractional ±1/16"
 .X= ±.1
 .XX=±.01
 .XXX=±.005
 .XXXX=±.0015

CONFIDENTIAL
 THIS DOCUMENT, INCLUDING ALL INFORMATION HEREIN, IS THE EXCLUSIVE AND CONFIDENTIAL PROPERTY OF ERNEST INDUSTRIES. THEREFORE THIS DOCUMENT IS NOT TO BE COPIED, REPRODUCED, OR DELIVERED TO OTHERS WITHOUT THE EXPRESS WRITTEN PERMISSION OF ERNEST INDUSTRIES.

Kelly-Creswell
 1221 Groop Rd.
 Springfield, OH 45504
 937-265-2979



DRAWN BY
 CDW
 APPROVED BY

DATE
 11-4-10
 DATE APPROVED

TITLE:
 POWER PRO

DESCRIPTION:
 SHIPPING DIMENSIONS

DWG NO./PART NO.
 POWER PRO ASSEMBLY

SCALE: N/A	SIZE: A	PAGE #: 3-3	REV: A
---------------	------------	----------------	-----------

Kelly-Creswell
 Power Pro
 Rev C