

# **SPECIFICATIONS**

## **B4 DOUBLE LINE STRIPING MACHINE**

### **Stainless Steel Tank, Non-Bleeder/Flush**

Part Number: PO-B4-SS (air actuated traction drive)

Part Number: PO-B4-SS-Hydro (hydrostatic wheel drive)

### **GENERAL**

The purpose of these specifications are to describe a self-propelled, self-contained double-line paint striping machine which is capable of applying marking paints of all kinds, both reflective and non-reflective types. The machine shall be completely self-contained, capable of being operated by a single operator.

### **EQUIPMENT**

1. **FRAME AND CHASSIS.** The frame shall be electrically welded, rigidly reinforced, heavy 1-1/16" and 1-5/16" OD tubular steel construction with steel engine deck. The engine deck will be constructed to allow for tension adjustment between the engine and compressor. The unit shall be 72" long, 42" wide and 48" height and weigh 560 pounds.
2. **ENGINE.** The marking machine shall be equipped with a single cylinder, four cycle, air cooled, gasoline engine capable of developing not less than 13 brake horsepower at 3600 RPM. The engine shall be equipped with a large 1-1/2 gallon fuel tank.
3. **COMPRESSOR.** The compressor shall be twin-cylinder, two stage, air-cooled type with a displacement of not less than 18 CFM at 80 psi gauge pressure and 900 rpm. The compressor shall be equipped with anti-friction tapered bearings, positive splash lubrication and provide sufficient air capacity for operating all components while maintaining a 50% air reserve at all times to facilitate long service life. The compressor shall be equipped with an after cooler manifold to insure pressurized air remains cool. The unit shall also be equipped with a heavy duty, stainless steel flexible main air line. The compressor shall be equipped with an automatic un-loader valve to maintain system pressure, use of pop off style valves prohibited.
4. **MATERIAL CONTAINER.** The marking machine shall be equipped with a material container of not less than 17 U. S. gallon capacity fabricated from stainless steel minimum grade 304. The tank tested to withstand an internal working pressure of not less than 110 PSI and shall be equipped with a drain off line and ball valve to completely empty the tank in a convenient location outside the frame. A tank shut off valve at the bottom of the tank shall also be provided. The material container shall be mounted in a vertical position, directly behind the compressor and engine. The tank lid shall be not less than 10" in diameter and of ASME construction. A solvent resistant gasket shall be held in place with four forged steel clamps and wing bolt assemblies. The tank shall further be equipped with all necessary gauges, regulators and safety pop-off valves. All plumbing coming in direct contact with paint shall be of stainless steel construction, minimum grade 304.

5. **SPRAY EQUIPMENT.** The spray system shall include two automatic air actuated KC-593-NBSS-F spray guns, designed specifically for application of traffic paints. The spray guns and material container shall be further equipped with three separate, non corrosive type regulators to maintain paint tank pressure and atomization air to each striping gun. The spray guns shall be automatic, diaphragm-operated, internal mixing, non-bleeder type capable of applying 3" to 9" lines. The spray guns shall be equipped with a hardened satellite air cap capable of spraying both reflective and non reflective type paints. The spray gun will further be equipped with automatic tip flush capability in the non-bleeder mode. The spray guns shall be further equipped with air curtain assembly to insure sharp line definition. The striping gun shall apply square beginnings and endings in uniform application and perfect cross distribution. All hoses (control, atomizing and fluid) to the striping gun shall be the solvent-resistant and equipped with reusable type fittings. The spray guns shall be mounted outboard at the left on a hinged side delivery **set up for two 4" lines with a 4" space unless otherwise noted.** The paint gun and air curtains shall fold 90 degrees for transport and storage.
6. **STRAINER.** A "Y" type strainer shall be installed in the paint supply line to insure the removal of skins and other foreign matter from the gun paint supply. The strainer shall be mounted directly under the paint tank complete with isolation ball valve for service while maintaining paint in the tank. The strainer and screen shall be of all stainless steel construction with re-usable nylon gasket. The strainer shall be easily accessible to the operator.
7. **WHEELS.** The rear wheels shall be not less than 4.00 x 8 tubeless type pneumatic equipped with 1-3/8" anti-friction roller bearings and mounted on 1" diameter axle. The front wheel shall be 3.00 x 5 tubeless type pneumatic tire equipped with 5/8" ball bearings mounted on a cast iron swivel fork. The swivel fork shall be equipped with ball bearings which allow the wheel to pivot 360 degrees in either direction.
8. **CLEANER EQUIPMENT.** The striper shall be equipped with an automatic pressure cleaner mechanism of not less than two quart capacity. The mechanism shall be equipped with an atomizing head for the automatic flushing of atomized cleaner solution through the atomization line to the spray head assembly of the striping gun(s). In addition, the pressure cleaner mechanism shall be valved so that it will be possible to flush cleaner solution through the fluid line to the striping gun(s), while maintaining paint in the material container.
9. **CONTROLS.** Each striping gun shall be controlled by a separate quick-as-a-wink (QAW) control valve and a master quick-as-a-wink control valve shall be provided to open and close both guns simultaneously.
10. **REGULATORS.** A total of four (4) non-corrosive type regulators with corresponding gauges shall be provided for independent regulation of each striping gun, material container and pneumatic swivel wheel.
11. **HOSES.** All material hoses shall be nylon core type with standard threaded reusable fittings. Material hose: 1/2" ID; atomization hose 5/16" ID; control hose 1/4" ID.

12. **SELF PROPELLED DRIVE SYSTEM.** Select 12A for standard air actuated traction drive (PO-B4-SS) or 12B hydrostatic drive (PO-B4-SS-Hydro)

12A. **TRACTION MECHANISM.** The marking machine shall be equipped with an automatic, air-actuated traction mechanism capable of propelling the unit at adjustable speeds of 2.5 to 5 miles per hour. The traction mechanism shall be actuated by a separate quick-as-a-wink control valve located on the handle bar within easy reach of the operator. The traction mechanism shall apply positive force to each rear wheel by means of a cast iron traction roller. Separate air cylinders for each rear wheel shall maintain constant, equal pressure to ensure straight lines. Front wheel type traction shall not be acceptable.

12B. **HYDROSTATIC DRIVE.** Hydrostatic drive system in lieu of traction drive, suited for hilly and rough terrain. Wheels are directly coupled to individual hydraulic drive motors powered by a separate closed loop hydraulic pump directly coupled to the gasoline engine. The drive system is equipped with a handle to control speed both forward and reverse.

13. **BRAKE.** A manual operated parking brake within easy reach of the operator shall be installed on the machine to lock rear wheel when unattended.
14. **OPERATORS RIDING TRAILER.** The machine shall be equipped with a 12" x 24" operator's riding trailer mounted on two 3.00 x 5 pneumatic tires with foot brake. (Stand on trailer)
15. **PNEUMATIC FRONT LOCKING SWIVEL WHEEL.** The marking machine shall be equipped with a pneumatic actuated front locking swivel wheel. The operator can unlock the swivel wheel for turning the machine or radius striping and lock the wheel for straight line striping. A toggle type control valve shall be conveniently located on the right handle of the machine to pneumatically engage and disengage the swivel lock. The unit will be equipped with a separate air regulator to control air pressure to the air cylinder lock. The swivel wheel assembly shall be equipped with a 1" thick machined aluminum base with slotted holes for adjustment. The air cylinder shall be captive on the aluminum block and feature a threaded stud with locking nuts to adjust the stroke
16. **BELT GUARD.** The line marking machine shall be equipped with an all-steel expanded metal belt and pulley guard.
17. **GUIDE.** An adjustable telescopic guide arm shall be provided, suitable for retracing of original layout work or chalk line following. The adjustable pointer shall be equipped with a replaceable rubber drag strap.
18. **PAINTING.** The line marking machine shall be painted Federal Highway Yellow.
19. **GUARANTEE.** The line marking machine as specified herein shall be guaranteed for a period of one year after the date of delivery and acceptance against defective parts and workmanship.

20. **PARTS LISTS AND MANUALS.** The unit shall be equipped with one complete set of operator's instructions and a repair parts list. The parts list shall include detailed drawings of all components installed on the unit including part numbers.

## OPTIONAL EQUIPMENT

Latex Compatible	PO-B4	See specs for PO-B4.
Operators Riding Trailer	AC-1255	Detachable sit on riding trailer complete with adjustable seat assembly, two each 3 X 5 wheel assemblies and foot brake in lieu of stand on riding trailer.
Engines	AC-1373	Honda GX-390 13 gross HP engine with electric complete with 12 VDC battery and key start in lieu of recoil start. Required when adding a M40D skipline controller.
Spray Equipment		
	AC-21NB (two required)	Binks 21 non-bleed gun in lieu of standard (no tip flush capability).
	AC-21B (two required)	Bink's 21 bleeder gun in lieu of standard (two required).
Agitator	AC-1130	Hand paddle agitator for 7 or 12 gallon tanks, plated carbon steel shaft with plastic paddles and hand crank.
	QM-1011-1-SS	SS shaft for AC-1130 (recommended for latex material).
Gravity Bead Dispenser		The bead dispenser shall be installed to operate automatically in conjunction with the striping gun by means of the same control valve. In addition, a shut-off valve shall be installed in the control line to the bead dispenser so that the striping gun may be operated independently. The bead dispenser shall be fully adjustable for the desired application ratio of pounds of beads per gallon of paint.
	AC-1052-6-B17	Two (2) 6" gravity bead dispensers, 100# hopper, control and charging hoses installed on machines equipped with 17 gallon paint tank.
	FF-6	Additional 6" gravity bead dispenser for application of beads on 18" wide airport lines. (requires AC-1052-6-B17).
Pressure Bead System	AC-1060-2	The pressure bead system shall be equipped with a 100# pressure bead tank complete with 10" lid assembly, air regulation system and moisture trap. Two (2) KC-593B pressure bead guns shall be provided and located behind each spray gun and will operate automatically in conjunction with the striping gun. The volume of beads shall be adjustable by altering pressure on the bead tank and adjustment of the needle stop in the pressure bead gun.
Hand Gun Assembly		
	AC-1010-2	Hand paint spray gun complete with 20' of 3/8" fluid hose, 20' of 5/16" air hose, hand gun valves, fittings and Bink's 2100 hand gun.
	AC-1040	Bink's 2001-B Hand Bead Gun with 20' Hose (Requires AC-1060-1).
	AC-1020	Hand gun take off valves only, stainless steel.
Skipline	AC-1225	The unit shall be equipped with the Kelly-Creswell Mark 40D electronic

Controller		skipline controller, no exceptions. The Mark 40D skipline controller shall control up to four paint and bead guns simultaneously; features include a bright 32 character digital LCD display, advance/retard with Posi-Cycle, single switch auxiliary paint/skip cycle, automatic calibration, speedometer/odometer, versatile three-mode pattern change preset, metric or US display, menu driven programming, heavy duty military specification components, non-volatile memory (no batteries required) and is equipped with totalizing digital footage counters. Controller (Requires AC-1373 electric start engine).
Paint Delivery Options		Unless specified, the B-4 comes standard with two spray guns mounted outboard on the left side of the machine set up for two 4 inch lines with a 4" space.
	AC-1650	Airport side delivery for solid 18" line. Includes special hinged gun carriage and air curtain manifold.
	AC-1610-1	Edgeline attachment, no paint or bead dispenser. Move paint and bead dispenser (gun) from centerline carriage. Includes special hinged side delivery mounted on the right side of the machine including air curtains for 1 gun.
	AC-1610-2	Edgeline attachment, no paint or bead dispensers. Move paint and bead dispensers (guns) from centerline carriage. Includes special hinged side delivery mounted on the right side of the machine including air curtains for 2 guns.
	AC-1610-3	Edgeline attachment, no paint or bead dispensers. Move paint and bead dispensers (guns) from centerline carriage. Includes special hinged side delivery mounted on the right side of the machine including air curtains for 3 guns.
Transport Trailer	AC-1260	Transport trailer, single axle trailer complete with fold down ramp and tie down straps for striping equipment.

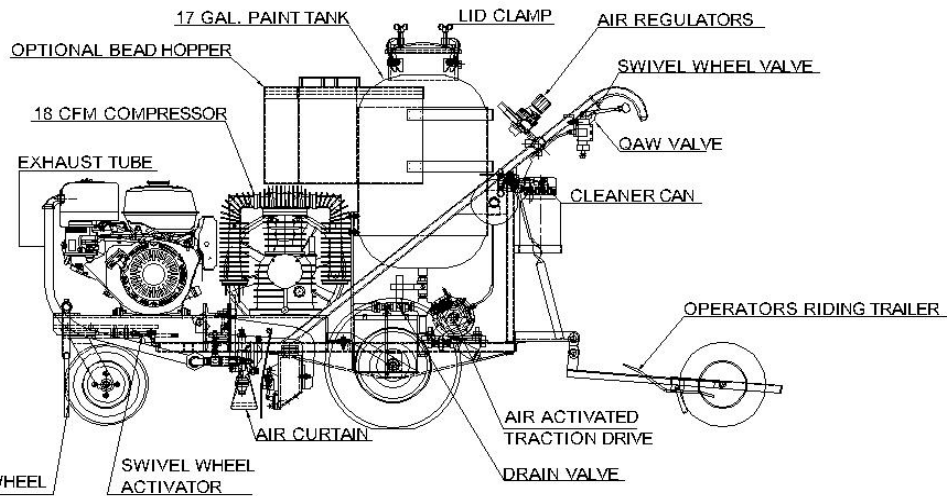
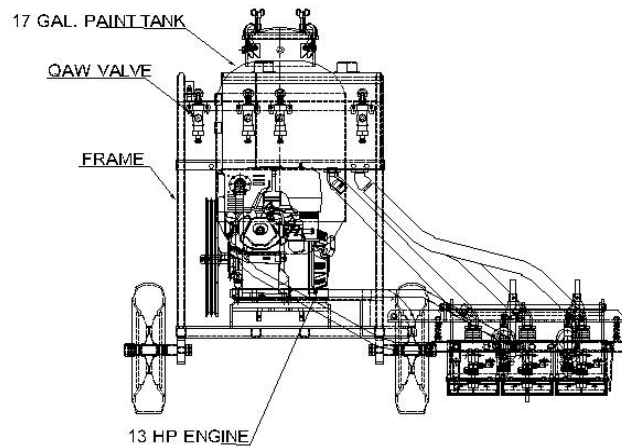
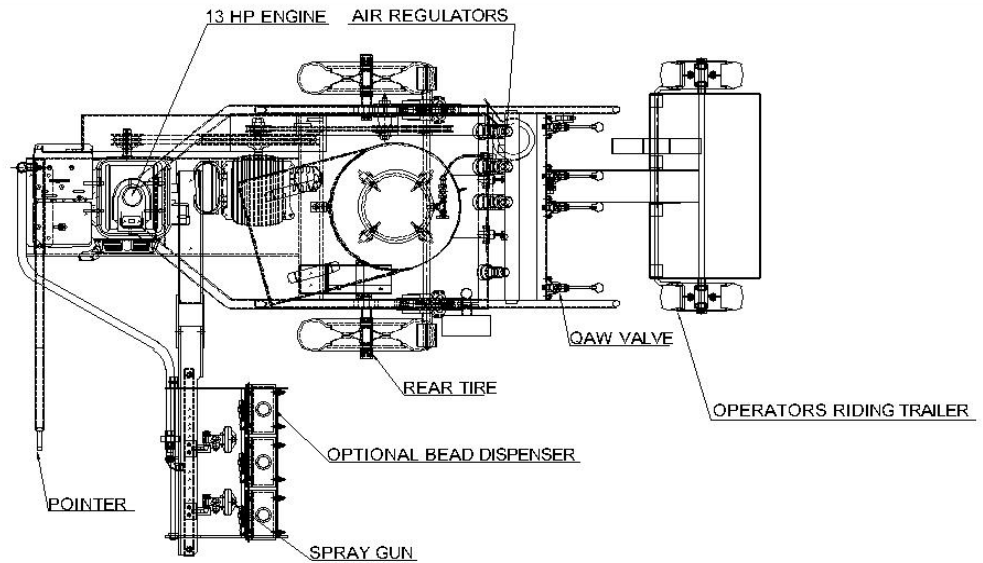

NOTE:  
STRIPER SHOWN WITH OPTIONAL AIRPORT SIDE  
DELIVERY BEAD SYSTEM

TOLERANCES UNLESS  
OTHERWISE SPECIFIED:  
Angular  $\pm 2^\circ$   
Fractional  $\pm 1/16"$   
X =  $\pm 1.1$   
XX =  $\pm 0.1$   
XXX =  $\pm 0.005$   
XXXX =  $\pm 0.015$

CONFIDENTIAL  
THIS DOCUMENT IS THE PROPERTY OF  
KELLY-CRESWELL INDUSTRIES, INC. AND IS  
THE EXCLUSIVE AND CONFIDENTIAL PROPERTY OF  
CRESWELL INDUSTRIES. THIS DOCUMENT IS  
NOT TO BE COPIED, REPRODUCED, OR  
DISSEMINATED TO OTHERS WITHOUT THE  
EXPRESS WRITTEN PERMISSION OF  
CRESWELL INDUSTRIES.

Kelly-Creswell  
1221 Groop Rd.  
Springfield, OH 45504



DRAWN BY  
CDW

DATE  
11-10-10

APPROVED BY

DATE APPROVED

TITLE:  
B4 DOUBLE LINE STRIPER

DESCRIPTION:  
GENERAL CALLOUTS

DWG. NO./PART NO.  
B4 TOP LEVEL A

SCALE:

SIZE:

PAGE #:

REV:

N/A

A

1-3

A

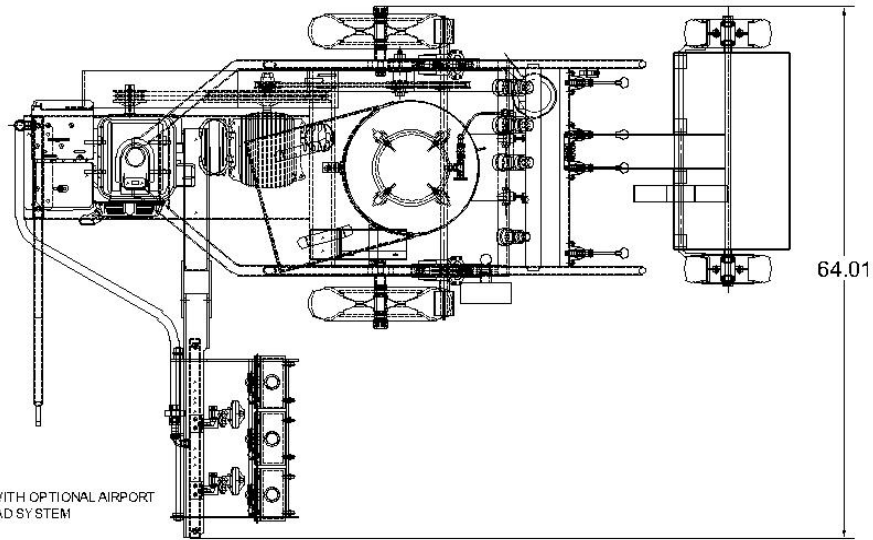

NOTE:  
STRIPER SHOWN WITH OPTIONAL AIRPORT  
SIDE DELIVERY BEAD SYSTEM

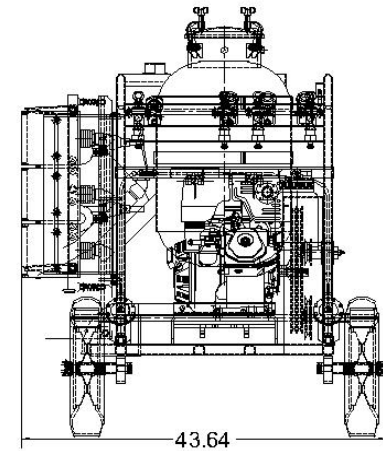
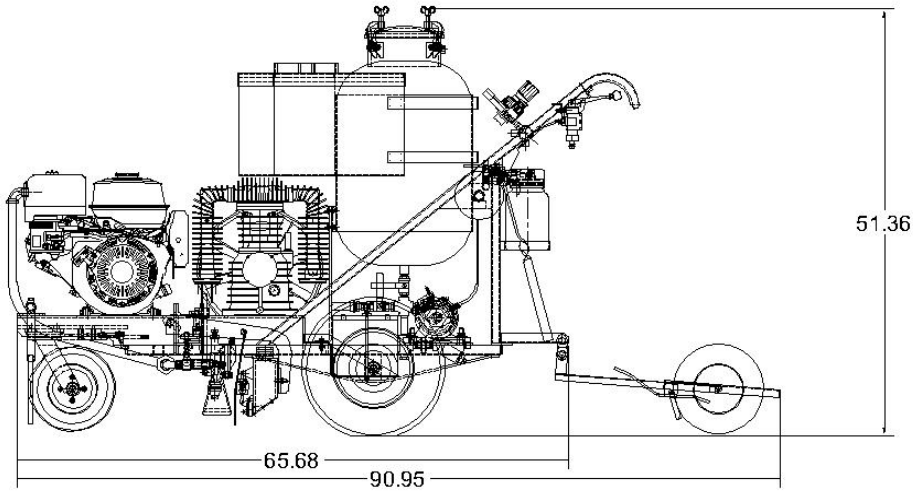

NOTE:  
SIDE DELIVERY OF STRIPER SHOWN IN  
TRANSPORT POSITION

TOLERANCES UNLESS  
OTHERWISE SPECIFIED:  
Angular ±2°  
Fractional ±1/16"  
X = ±.1  
XX = ±.01  
XXX = ±.005  
XXXX = ±.0015

CONFIDENTIAL  
THIS DOCUMENT INCLUDING  
ALL INFORMATION HEREIN IS  
THE EXCLUSIVE AND  
CONFIDENTIAL PROPERTY OF  
CRESWELL INDUSTRIES  
THEREFORE THIS DOCUMENT IS  
NOT TO BE COPIED,  
REPRODUCED, OR DISSEMINATED  
TO OTHERS WITHOUT THE  
EXPRESS WRITTEN PERMISSION OF  
CRESWELL INDUSTRIES.

Kelly-Creswell  
1221 Groop Rd.  
Springfield, OH 45504



DRAWN BY  
CDW

APPROVED BY

DATE  
11-9-10

DATE APPROVED

TITLE:

**B4 DOUBLE LINE STRIPER**

DESCRIPTION:

**BASIC DIMENSIONS**

DWG. NO./PART NO.

**B4 TOP LEVEL A**

SCALE:  
N/A

SIZE:  
A

PAGE #:  
2-3

REV:  
A

**Kelly-Creswell**  
**B4-SS**  
**Rev C**



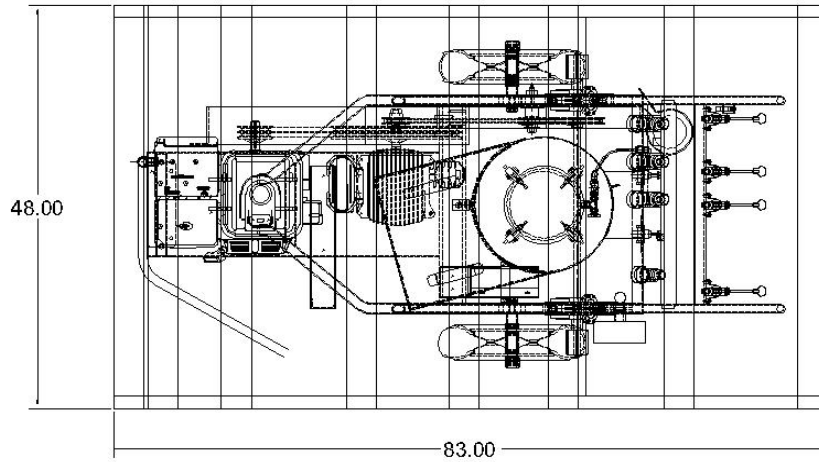

LENGTH (INCHES)	83"
WIDTH (INCHES)	48"
HEIGHT (INCHES)	55.5"
EST. SHIPPING WEIGHT	800 LBS
APPROX. CUBIC FEET	125'

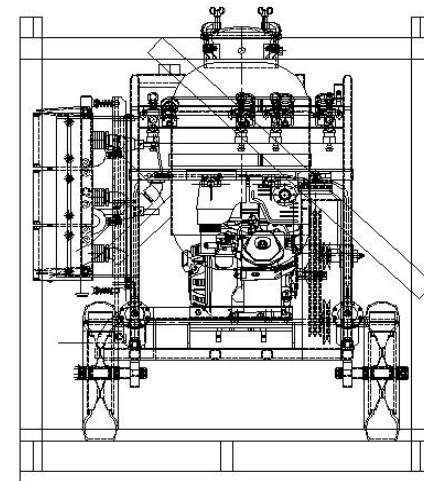
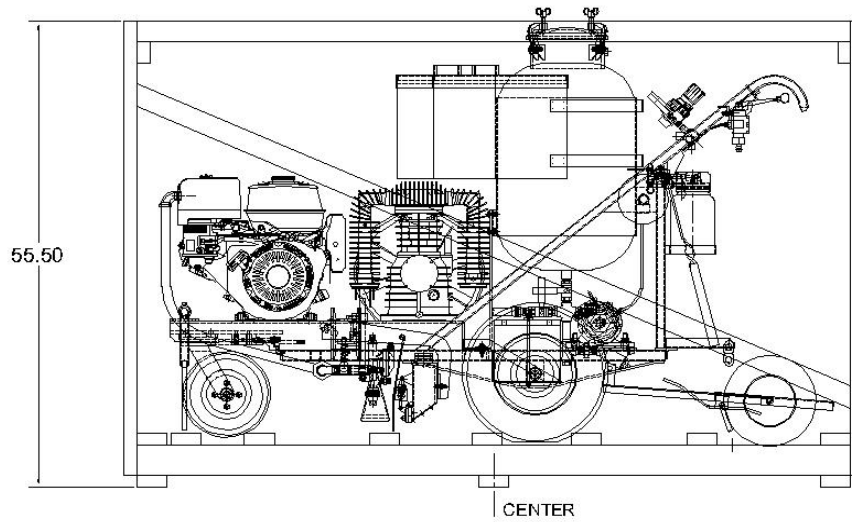

TOLERANCES UNLESS OTHERWISE SPECIFIED:  
 Angular ±2°  
 Fractional ±1/16"  
 X = ±.1  
 XX = ±.01  
 XXX = ±.005  
 XXXX = ±.0015

CONFIDENTIAL  
 THIS DOCUMENT IS UNCLASSIFIED  
 ALL INFORMATION HEREIN IS  
 THE EXCLUSIVE AND  
 CONFIDENTIAL PROPERTY OF  
 CRUEST INDUSTRIES  
 THEREFORE THIS DOCUMENT IS  
 NOT TO BE COPIED,  
 REPRODUCED, OR DISSEMINATED  
 TO OTHERS WITHOUT THE  
 EXPRESS WRITTEN PERMISSION  
 OF CRUEST INDUSTRIES.

Kelly-Creswell  
 1221 Groop Rd.  
 Springfield, OH 45504



DRAWN BY  
 CDW

DATE  
 11-9-10

APPROVED BY

DATE APPROVED

TITLE:  
 B4 DOUBLE LINE STRIPER

DESCRIPTION:  
 SHIPPING DIMENSIONS

DWG. NO./PART NO.  
 B4 TOP LEVEL

SCALE:  
 N/A

SIZE:  
 A

PAGE #:  
 3-3

REV:  
 A

Kelly-Creswell  
 B4-SS  
 Rev C